

FAG



FAG Heating Devices for the Mounting of Rolling Bearings

Induction heating devices HEATER and
heating plate HEATER-PLATE

SCHAEFFLER



Foreword

Schaeffler Technologies AG & Co. KG is a leading worldwide supplier of rolling bearings, spherical plain bearings, plain bearings, linear products, accessories specific to bearings and comprehensive maintenance products and services. It has approximately 40 000 catalogue products manufactured as standard, providing an extremely wide portfolio that gives secure coverage of applications from all 60 industrial market sectors.

Industrial Service

This Technical Product Information is aimed principally at maintenance managers and operators of plant in which rolling bearings and other rotating machine components play a critical role in determining the quality of products and processes. Those responsible for maintenance and production processes must be able to rely every day on the quality of their tools and the expertise of their service providers.

Industrial Aftermarket

Schaeffler Industrial Aftermarket (IAM) is responsible for conducting the replacement parts and service business for end customers and sales partners in all significant industrial sectors. On the basis of innovative solutions, products and services relating to rolling and plain bearings as well as intelligent implementation of the Total Cost of Ownership (TCO) philosophy, the Industrial Aftermarket service function offers a comprehensive portfolio that covers all phases in the lifecycle of the rolling bearing.

The aim is to help customers save on maintenance costs, optimise plant availability and avoid unforeseen machine downtime.

Schaeffler has centres of competence all around the world. This means we can provide customers worldwide with products, services and training quickly and professionally. All service employees undergo a comprehensive training programme and are audited regularly. This ensures that services throughout the world conform to a uniformly high standard of quality.

Every request, every task is different, so the Industrial Aftermarket function offers an individual concept for each customer.

The quality requirements are strongly influenced by a long history of high precision rolling bearing manufacture. The production and provision of all products and services in this catalogue is proven in practice and is secured by a quality management system certified to ISO 9001:2008.

Mounting of rolling bearings

Expansion through heating

Where tight fits are to be achieved on cylindrical bearing seats, it is advisable to heat bearings for mounting. Sufficient expansion is achieved with a temperature differential of +80 °C to +100 °C. A large number of FAG heating devices are available for use with different bearing sizes.

When heating the bearings, the temperature must be precisely monitored. It must not under any circumstances increase to more than +120 °C. Protective gloves should be worn while mounting the heated rolling bearings.

Suitable accessories such as temperature measuring devices, protective gloves and transport and mounting tools can assist significantly with the reliable thermal mounting of rolling bearings.

Functional principle

The principle of the heating device is based on a current-carrying coil with an iron core (primary coil), which generates a high induction current at low voltage in a short-circuited secondary circuit (rolling bearing or other steel part), *Figure 1*. As a result, the rolling bearing to be mounted is heated, while the non-metallic parts and the device itself remain cold.

- ① Primary coil
- ② Secondary circuit
- ③ U-shaped iron core
- ④ Support ledge
- ⑤ Electromagnetic field

Figure 1
Functional principle

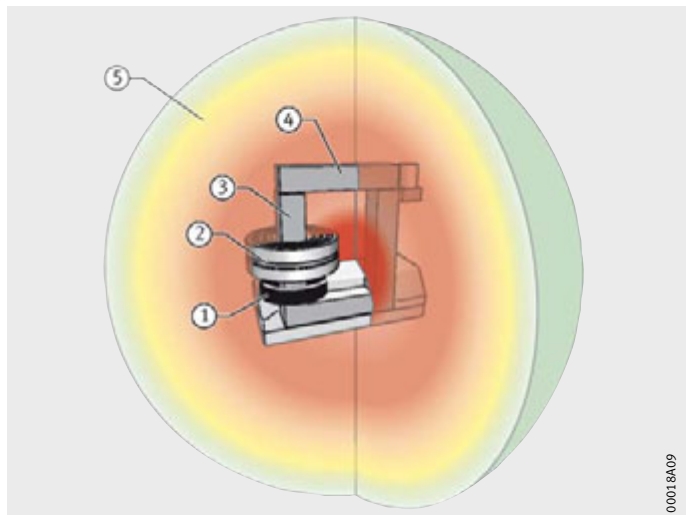

Application

Many rolling bearings are mounted with a tight fit on the shaft. The mounting of larger rolling bearings in particular is significantly easier if they are heated beforehand (up to a maximum of +120 °C). Induction heating is superior to the conventional methods (heating furnace, heating plate, oil bath).

Induction heating methods are suitable for rolling bearings and other ring-shaped ferromagnetic steel parts. They are also suitable for frequent heating.

Heating can be used on:

- complete bearings
- inner rings of cylindrical roller bearings or needle roller bearings.

The advantages of induction heating include:

- environmentally friendly operation without the use of oil (no disposal required)
- rapid and clean operation of induction heating devices.

FAG Heating Manager

The software FAG Heating Manager is a user-friendly tool for selection of the optimum heating device for the heating of rolling bearings.

Once the rolling bearing to be heated has been selected, the bearing type, dimensions, mass and the suitable heating device are shown, *Figure 2*.

If the rolling bearing to be heated is not in the database, the suitable heating device can be determined by manual input of the dimensions and mass.

On the basis of a special algorithm, the software determines the optimum heating device for the selected bearing. In addition to the preferred heating device, possible alternative devices are indicated that can also be used for the selected bearing. However, these heating devices may be subject to certain restrictions, such as a longer heating time.

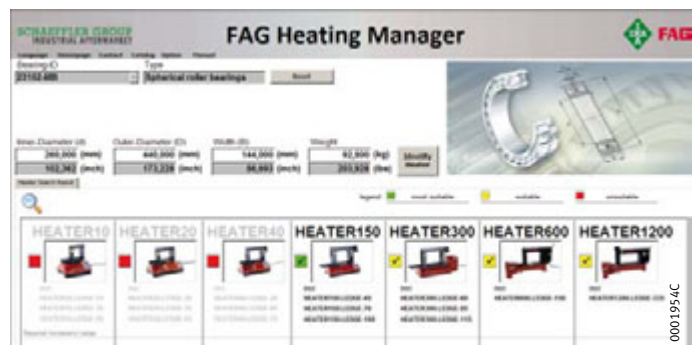

Figure 2
FAG Heating Manager

Mounting of rolling bearings

Positioning of rolling bearings

If tabletop devices are used for heating, the rolling bearings can be either laid horizontally on the support rails or suspended vertically from the horizontal ledge, *Figure 3*.

For heating of a rolling bearing, it should preferably be laid on the support rails.

- ① Ledge
- ② U-shaped core
- ③ Rolling bearing
- ④ Support rail

Figure 3
Positioning of rolling bearings



Selecting the ledge

When heating the rolling bearing, the bearing bore should be filled to the optimum extent. The larger the cross-section of the ledge that is used, the shorter the heating time, *Figure 4*.

- ① Small ledge cross-section
- ② Large ledge cross-section

Figure 4
Selecting the ledge



Attaching the temperature sensor

In the case of rolling bearings, the magnetic temperature sensor should be attached over its whole surface to the end face of the inner ring as close as possible to the bearing bore, *Figure 5*. Before it is attached, any grease or oil residues must be removed from the end face.

- ① Inner ring of rolling bearing
- ② Temperature sensor
- ③ Cable of temperature sensor
- ④ Socket for temperature sensor
- ⑤ Plug of temperature sensor

Figure 5
Attaching the temperature sensor

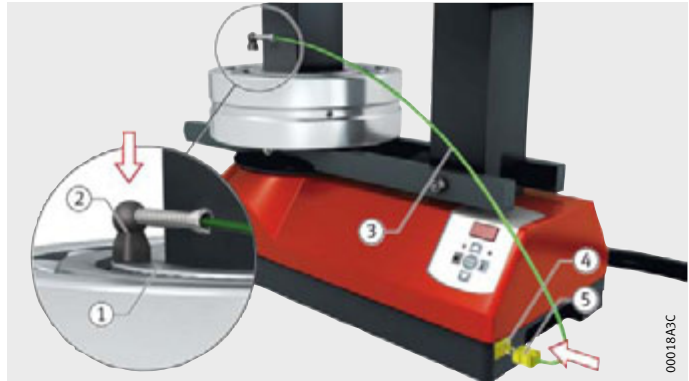

Contents

	Page
Product overview	Heating devices HEATER..... 8
Features	Features 10
	Heating device HEATER10 14
	Heating device HEATER20 16
	Heating device HEATER40 18
	Heating device HEATER150 20
	Heating device HEATER300 22
	Heating device HEATER600 24
	Heating device HEATER1200 26
	Special designs 27
	Heating plate HEATER-PLATE 28
	Accessories for thermal mounting 29
	Other applications 33
Design and safety guidelines	Safety and reliability 34
	Conformity 36
Dimension tables	Heating devices HEATER, product range..... 38
Appendix	Checklist for selection of heating devices HEATER..... 43

Product overview Heating devices HEATER

Tabletop devices

HEATER10



HEATER20



HEATER40



HEATER150



HEATER300



Standalone devices

HEATER600



00018A0A

HEATER1200



00018A0B

Heating plate

HEATER-PLATE



0001918D

Heating devices HEATER

Features The heating devices HEATER can be used to heat rolling bearings safely and economically, *Figure 1*.

For smaller bearings and machine parts (max. 5 kg), the electric heating plate HEATER-PLATE is particularly suitable.

The induction heating devices HEATER for rolling bearings up to a mass of 1200 kg have been improved further in terms of their performance capability and safety compared with their predecessors. They can also be used to heat sealed and greased rolling bearings. In addition to the tabletop devices HEATER10 to HEATER300, the range also includes the standalone devices HEATER600 and HEATER1200 for larger rolling bearings. HEATER300 can also be converted to a mobile unit by means of accessories.



Figure 1
Scope of delivery
Induction heating device HEATER

The rolling bearing to be heated is either placed horizontally on the support rails or is suspended on the ledge.

The contact surfaces of the ledge are ground, so there is only slight loss of power.

The clearly laid out control panels on the heating devices can also be operated using protective gloves. The membrane keyboard is oil-resistant, dustproof and waterproof. All operating modes (temperature, time and ramp control) and functions can be controlled using the keys. The operating modes are identified by clear symbols on the keys.

The basic version of the heating device is supplied with a magnetic temperature sensor which can be used up to +240 °C (484 °F).

Advantages of FAG heating devices

The advantages of induction heating devices are as follows:

- very safe operation
- high reliability (TÜV certified)
- effective, energy-efficient heating (high efficiency level)
- uniform, controlled heating
- automatic demagnetisation
- simple operation
- high cost-effectiveness through selection of the device size most suitable for the particular application.

The heating devices have various functions, see table.

Functions

Function	HEATER						
	10	20	40	150	300	600	1200
Demagnetisation	●	●	●	●	●	●	●
Program shutdown	●	●	●	●	●	●	●
Display of actual temperature value	●	●	●	●	●	●	●
Temperature display in °C or °F	●	●	●	●	●	●	●
Display of actual temperature value and time	–	–	●	●	●	●	●

Operating modes

The induction heating devices can be operated in the following modes:

- temperature control
- time control
- ramp control.

Temperature control

When using temperature control, the heating temperature can be set to a value between +40 °C and +240 °C (for rolling bearings, a maximum of +120 °C), *Figure 2*, page 12. The heating operation is started using the Start key.

When the target temperature is reached, an acoustic signal is emitted and the display flashes. The device holds the workpiece at the preselected temperature. When the Stop key is pressed, the heating process terminates and the part is automatically demagnetised. Temperature control is suitable when rapid heating is required without damaging the rolling bearing.

Heating devices HEATER

- ① Initial temperature
- ② Heating temperature
- ③ Temperature of inner ring
- ④ Temperature of outer ring
- ⑤ Heating time

Figure 2
Temperature control

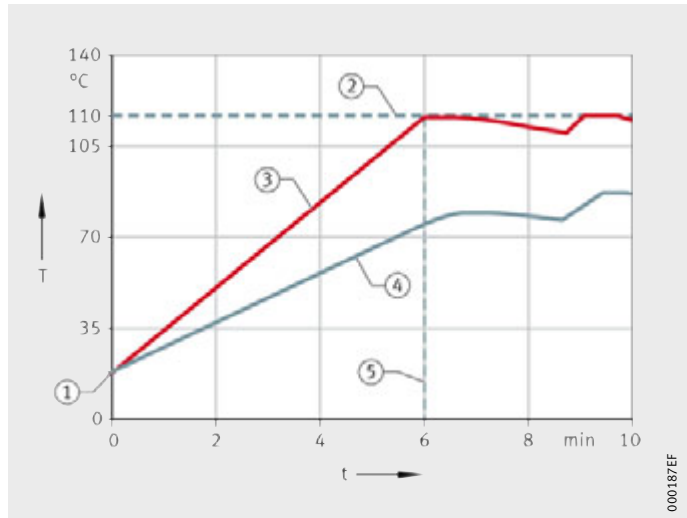

Time control

When using time control, the heating time can be set steplessly up to 99:59 min, Figure 3. Once this time has expired, the rolling bearing is automatically demagnetised. Completion of the demagnetisation process is indicated not only on the display but also by means of an acoustic signal. The use of time control is recommended for batch mounting of identical rolling bearings (with a constant heating time). When using time control, the temperature sensor is not necessary.

- ① Initial temperature
- ② Heating temperature
- ③ Temperature of inner ring
- ④ Temperature of outer ring
- ⑤ Heating time

Figure 3
Time control

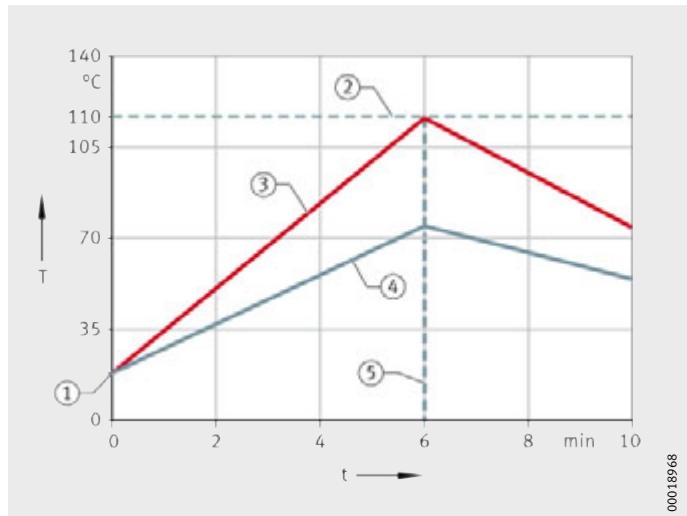

Ramp control

When using ramp control, the heating temperature is set for a defined time, in order that the rolling bearing is heated to the set temperature over the set time period in a controlled manner, *Figure 4*. As a result, the outer ring of the rolling bearing also has sufficient time for heating. The controller continuously monitors both the time and temperature and adjusts the power level accordingly. Ramp control is suitable for use where the bearing has reduced radial internal clearance. Since there is only a slight temperature differential between the inner and outer ring of the rolling bearing, stresses and raceway damage due to rolling element indentation are avoided.

Ramp control is particularly suitable for thick-walled workpieces, since wide temperature differentials between the inner and outer ring in these cases may lead to material stresses.

- ① Initial temperature
- ② Heating temperature
- ③ Temperature of inner ring
- ④ Temperature of outer ring
- ⑤ Heating time

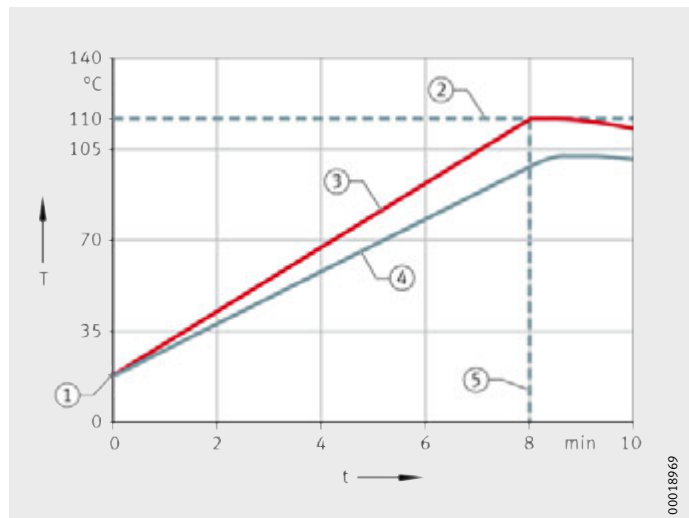

Figure 4
Ramp control

Heating devices HEATER

Heating device HEATER10

The induction heating device HEATER10 is suitable for rolling bearings from a bore diameter of 15 mm (with the aid of accessories, from 10 mm) and a mass of up to 10 kg, *Figure 5*.

The heating device has a sturdy, scratch-resistant polyurethane housing. It can be easily moved thanks to its lateral handholds.

The heating device with its three support ledges and a magnetic temperature sensor can be easily transported. In conjunction with the optional transport case, it is therefore particularly suitable for mobile mounting operations, *Figure 6*, page 15.

The heating device can be connected to any standard two-pin safety socket which is protected by a 10 A fuse.

The heating device operates by means of temperature control.

Scope of delivery

Description	Designation	Dimensions mm	Bore diameter from mm	Mass kg
Heating device	HEATER10	–	–	–
Support ledge	HEATER10.LEDGE-15	10×10×125	15	0,08
	HEATER10.LEDGE-30	20×20×125	30	0,15
	HEATER10.LEDGE-45	30×30×125	45	0,15
Temperature sensor	HEATER.SENSOR-400MM	–	–	0,05
Rolling bearing grease	ARCANOL-MULTI3-250G	–	–	0,3
Protective gloves	GLOVE-PRO-TEMP	–	–	0,3
Cover	HEATER10.COVER	–	–	–



Figure 5
Heating device HEATER10

00018C1B

Accessories In the case of rolling bearings with intermediate sizes, further support ledges are available as accessories in order to optimise the heating operation, see table.

Accessories

Description	Designation	Dimensions	Bore diameter from	Mass
		mm	mm	kg
Support ledge	HEATER10.LEDGE-10	7×7×125	10	0,04
	HEATER10.LEDGE-20	14×14×125	20	0,3
Transport case	HEATER10.CASE	–	–	–



Figure 6
Transport case HEATER10.CASE

Heating devices HEATER

Heating device HEATER20

The induction heating device HEATER20 is suitable for rolling bearings from a bore diameter of 20 mm (with the aid of accessories, from 10 mm) and a mass of up to 20 kg, *Figure 7*.

The heating device has a sturdy, scratch-resistant polyurethane housing. It can be easily moved thanks to its lateral handholds.

The heating device with its three support ledges and a magnetic temperature sensor can be easily transported. In conjunction with the optional transport case, it is therefore particularly suitable for mobile mounting operations, *Figure 8*, page 17.

The heating device can be connected to any standard two-pin safety socket which is protected by a 16 A fuse.

The heating device operates by means of temperature control.

Scope of delivery

Description	Designation	Dimensions	Bore diameter	Mass
		mm	from mm	kg
Heating device	HEATER20	–	–	–
Support ledge	HEATER20.LEDGE-20	14×14×200	20	0,3
	HEATER20.LEDGE-35	25×25×200	35	0,9
	HEATER20.LEDGE-60	40×40×200	60	2,5
Temperature sensor	HEATER.SENSOR-400MM	–	–	0,05
Rolling bearing grease	ARCANOL-MULTI3-250G	–	–	0,3
Protective gloves	GLOVE-PRO-TEMP	–	–	0,3
Cover	HEATER20.COVER	–	–	–



Figure 7
Heating device HEATER20

00018C1D

Accessories In the case of rolling bearings with intermediate sizes, further support ledges are available as accessories in order to optimise the heating operation, see table.

Accessories

Description	Designation	Dimensions	Bore diameter from mm	Mass kg
		mm		
Support ledge	HEATER20.LEDGE-10	7×7×200	10	0,08
	HEATER20.LEDGE-15	10×10×200	15	0,15
	HEATER20.LEDGE-45	30×30×200	45	1,35
Support rail	HEATER20.BLADE-XL	15×20×320	–	0,8
Transport case	HEATER20.CASE	–	–	–



Figure 8
Transport case HEATER20.CASE

Heating devices HEATER

Heating device HEATER40

The induction heating device HEATER40 is suitable for rolling bearings from a bore diameter of 20 mm (with the aid of accessories, from 15 mm) and a mass of up to 40 kg, *Figure 9*.

The heating device has a sturdy, scratch-resistant polyurethane housing. It can be easily moved thanks to its lateral handholds.

The heating device can be connected to any standard two-pin safety socket which is protected by a 16 A fuse.

The heating device is switched on and off by means of a remote control unit.

Scope of delivery

Description	Designation	Dimensions mm	Bore diameter from mm	Mass kg
Heating device	HEATER40	–	–	–
Support ledge	HEATER40.LEDGE-20	14×14×280	20	0,4
Slewing ledge	HEATER40.LEDGE-45	30×30×280	45	1,8
	HEATER40.LEDGE-70	50×50×280	70	5,3
Temperature sensor	HEATER.SENSOR-1000MM	–	–	0,05
Rolling bearing grease	ARCANOL-MULTI3-250G	–	–	0,3
Protective gloves	GLOVE-PRO-TEMP	–	–	0,3
Cover	HEATER40.COVER	–	–	–



Figure 9
Heating device HEATER40

Accessories In the case of rolling bearings with intermediate sizes, further support ledges are available as accessories in order to optimise the heating operation, see table.

Accessories

Description	Designation	Dimensions	Bore diameter from mm	Mass kg
		mm		
Support ledge	HEATER40.LEDGE-15	10×10×280	15	0,2
Slewing ledge	HEATER40.LEDGE-35	25×25×280	35	1,3
	HEATER40.LEDGE-60	40×40×280	60	3,4
Support rail	HEATER40.BLADE-XL	15×20×430	–	1,1

Heating devices HEATER

Heating device HEATER150

The induction heating device HEATER150 is suitable for rolling bearings from a bore diameter of 45 mm (with the aid of accessories, from 20 mm) and a mass of up to 150 kg, *Figure 10*.

The heating device has a sturdy, scratch-resistant polyurethane housing.

The heating device is switched on and off by means of a remote control unit.

Scope of delivery

Description	Designation	Dimensions mm	Bore diameter from mm	Mass kg
Heating device	HEATER150	–	–	–
Slewing ledge	HEATER150.LEDGE-45	30×30×350	45	2,4
	HEATER150.LEDGE-70	50×50×350	70	6,6
	HEATER150.LEDGE-100	70×70×350	100	12,8
Temperature sensor	HEATER.SENSOR-1000MM	–	–	0,05
Rolling bearing grease	ARCANOL-MULTI3-250G	–	–	0,3
Protective gloves	GLOVE-PRO-TEMP	–	–	0,3
Cover	HEATER150.COVER	–	–	–



Figure 10
Heating device HEATER150

Accessories In the case of rolling bearings with intermediate sizes, further support ledges are available as accessories in order to optimise the heating operation, see table.

Accessories

Description	Designation	Dimensions	Bore diameter from mm	Mass
		mm		kg
Support ledge	HEATER150.LEDGE-20	14×14×350	20	0,5
Slewing ledge	HEATER150.LEDGE-30	20×20×350	30	1,1
	HEATER150.LEDGE-60	40×40×350	60	4,2
	HEATER150.LEDGE-85	60×60×350	85	9,4

Heating devices HEATER

Heating device HEATER300

The induction heating device HEATER300 is suitable for rolling bearings from a bore diameter of 60 mm (with the aid of accessories, from 30 mm) and a mass of up to 300 kg, *Figure 11*.

The heating device has a sturdy, scratch-resistant polyurethane housing.

The heating device is switched on and off by means of a remote control unit.

Scope of delivery

Description	Designation	Dimensions mm	Bore diameter from mm	Mass kg
Heating device	HEATER300	–	–	–
Slewing ledge	HEATER300.LEDGE-60	40×40×490	60	5,9
	HEATER300.LEDGE-85	60×60×490	85	13,2
	HEATER300.LEDGE-115	80×80×490	115	23,5
Temperature sensor	HEATER.SENSOR-1000MM	–	–	0,05
Rolling bearing grease	ARCANOL-MULTI3-250G	–	–	0,3
Protective gloves	GLOVE-PRO-TEMP	–	–	0,3
Cover	HEATER300.COVER	–	–	–



Figure 11
Heating device HEATER300

Accessories In the case of rolling bearings with intermediate sizes, further slewing ledges are available as accessories in order to optimise the heating operation, see table.

Accessories

Description	Designation	Dimensions	Bore diameter from mm	Mass kg
		mm		
Slewing ledge	HEATER300.LEDGE-30	20×20×490	30	1,5
	HEATER300.LEDGE-45	30×30×490	45	3,3
	HEATER300.LEDGE-70	50×50×490	70	9,2
	HEATER300.LEDGE-100	70×70×490	100	18
Trolley	HEATER300.TROLLEY	900×500×490	–	25

The heating device can be transported quickly and safely from one application to another using the trolley HEATER300.TROLLEY, *Figure 12*. The trolley can also be used for storage of the slewing ledges.



Figure 12
Trolley HEATER300.TROLLEY

Heating devices HEATER

Heating device HEATER600

The induction heating device HEATER600 is suitable for heating rolling bearings from a bore diameter of 145 mm (with the aid of accessories, from 45 mm) and a mass of up to 600 kg, *Figure 13*.

The base frame is a steel construction and the housing is made from high quality laminate.

The vertical ledge is lifted manually or using hoisting equipment. The bearing is placed and centred on the support rails by means of the sliding table supplied before the vertical ledge is lowered and locked into place.

With the aid of the sliding table supplied, the rolling bearing can be easily moved into the correct position for heating.

The heating device is switched on and off by means of a remote control unit.

Scope of delivery

Description	Designation	Dimensions mm	Bore diameter from mm	Mass kg
Heating device	HEATER600	–	–	–
Vertical ledge	HEATER600.LEDGE-150	100×112×700	150	61,5
Temperature sensor	HEATER.SENSOR-1000MM	–	–	0,05
Rolling bearing grease	ARCANOL-MULTI3-250G	–	–	0,3
Protective gloves	GLOVE-PRO-TEMP	–	–	0,3
Cover	HEATER600.COVER	–	–	–
Sliding table	HEATER600.SLIDING-TABLE	–	–	–



Figure 13
Heating device HEATER600

00018CZ5

Figure 14
Heating device HEATER600
(with sliding table)



Accessories

In the case of rolling bearings with intermediate sizes, further ledges are available as accessories in order to optimise the heating operation, see table.

Accessories

Description	Designation	Dimensions	Bore diameter from mm	Mass kg
		mm		
Vertical ledge	HEATER600.LEDGE-55	30×42×700	55	6,9
	HEATER600.LEDGE-65	40×52×700	65	13,7
	HEATER600.LEDGE-80	50×62×700	80	17
	HEATER600.LEDGE-95	60×72×700	95	23,7
	HEATER600.LEDGE-110	70×82×700	110	31,5
	HEATER600.LEDGE-125	80×92×700	125	40,4
	HEATER600.LEDGE-140	90×102×700	140	50

Variants

The heating device HEATER600 is available in further variants:

- HEATER600-LIFT with a hoisting device for the vertical ledge
- HEATER600 in a mobile version with a chassis on rollers.

Heating devices HEATER

Heating device HEATER1200

The induction heating device HEATER1200 is suitable for heating rolling bearings from a bore diameter of 215 mm (with the aid of accessories, from 85 mm) and a mass of up to 1200 kg, *Figure 15*.

The base frame is a steel construction and the housing is made from high quality laminate.

The vertical ledge is lifted manually or using hoisting equipment, *Figure 15*. The bearing is placed and centred on the support rails by means of the sliding table supplied before the vertical ledge is lowered and locked into place.

With the aid of the sliding table supplied, the rolling bearing can be easily moved into the correct position for heating.

The heating device is switched on and off by means of a remote control unit.

Scope of delivery

Description	Designation	Dimensions	Bore diameter from	Mass
		mm	mm	kg
Heating device	HEATER1200	–	–	–
Vertical ledge	HEATER1200.LEDGE-225	150×162×850	225	157
Temperature sensor	HEATER.SENSOR-1000MM	–	–	0,05
Rolling bearing grease	ARCANOL-MULTI3-250G	–	–	0,3
Protective gloves	GLOVE-PRO-TEMP	–	–	0,3
Cover	HEATER1200.COVER	–	–	–
Sliding table	HEATER1200.SLIDING-TABLE	–	–	–

The device is supplied without a plug and cable.



Figure 15
Heating device HEATER1200

00018C27

Figure 16
Heating device HEATER1200
(with sliding table)



Accessories

In the case of rolling bearings with intermediate sizes, further ledges are available as accessories in order to optimise the heating operation, see table.

Accessories

Description	Designation	Dimensions mm	Bore diameter from mm	Mass kg
Vertical ledge	HEATER1200.LEDGE-95	60×72×850	95	28,8
	HEATER1200.LEDGE-125	80×92×850	125	49,1
	HEATER1200.LEDGE-150	100×112×850	150	74,7
	HEATER1200.LEDGE-180	125×137×850	180	105

Variants

The heating device HEATER1200 is available in further variants:

- HEATER1200-LIFT with a hoisting device for the vertical ledge
- HEATER1200 in a mobile version with a chassis on rollers.

Special designs

Special designs of induction heating devices HEATER10 to HEATER1200 are available by agreement.

Heating devices HEATER

Heating plate HEATER-PLATE

The temperature-controlled FAG heating plate HEATER-PLATE can be used to heat rolling bearings (up to a maximum of +120 °C) or small machine parts with a mass of up to 5 kg, *Figure 17*. The removable housing cover protects the workpieces from contaminants and ensures uniform and rapid heating. This economical device is maintenance-free and easy to handle.



Figure 17
FAG heating plate HEATER-PLATE

Technical data

Characteristic	Unit	Value
Dimensions (W×D×H)	mm	390×270×156
Plate size	mm	380×180
Maximum power	W	1 500
Voltage	V	230
Frequency	Hz	50
Temperature control	–	Stepless adjustment from +50 °C to +200 °C
Mass	kg	5,6

Available heating plates

Description	Designation
Heating plate	HEATER-PLATE
Heating plate for 115 V/60Hz	HEATER-PLATE-115V

Accessories for thermal mounting

The following accessories are recommended for thermal mounting:

- heat-resistant protective gloves (included in the scope of delivery of the heating devices)
- rolling bearing grease (included in the scope of delivery of the heating devices)
- transport and mounting tool BEARING-MATE
- FAG infrared thermometer TEMP-CHECK-PRO.

Heat-resistant and oil-resistant gloves

Heat-resistant and oil-resistant gloves are particularly suitable for the handling of heated and lubricated rolling bearings in mounting or dismantling. Their special characteristics are the result of their multi-layered construction comprising different fibres.

Their particular features are as follows:

- resistant up to +200 °C
- non-flammable
- heat-resistant even when damp
- authorised to DIN EN 388 against mechanical influences and to DIN EN 407 against thermal influences
- cotton-free
- cut-resistant.

The gloves are included as standard in the scope of delivery of the heating devices HEATER10 to HEATER1200 and the transport and mounting tool BEARING-MATE. They can also be ordered separately.

Available gloves

Description	Designation
Heat-resistant and oil-resistant gloves	GLOVE-PRO-TEMP



Figure 18
Heat-resistant and oil-resistant gloves GLOVE-PRO-TEMP

Heating devices HEATER

Rolling bearing grease ARCANOL-MULTI3

If the contact surfaces of the support ledges are coated with rolling bearing grease, this will improve heat transfer and reduce the noise level. A tube of rolling bearing grease is included as standard in the scope of delivery of the heating devices HEATER10 to HEATER1200, *Figure 19*. Further tubes can be ordered separately.

Ordering designation

■ ARCANOL-MULTI3-250G



Figure 19
Rolling bearing grease
ARCANOL-MULTI3-250G

Transport and mounting tool BEARING-MATE

BEARING-MATE is an accessory for the secure, rapid and easy handling of medium-sized and large rolling bearings. It can also be used where bearings are heated prior to mounting.

The tool comprises two handles and two steel strips. Turning the handles clamps the steel strips firmly on the outer ring of the rolling bearing. The compact packaging also includes two brackets. These are used, for example, on self-aligning ball bearings and spherical roller bearings in order to prevent tilting of the inner rings. The tool and bearing are carried either by two people or a crane. If two carrying slings are used, the rolling bearing can be rotated to any position when transported by crane. During heating on an induction heating device, the tool remains mounted on the bearing. The steel strips expand uniformly with the bearing. Optimum tension is thus maintained.

In order to accommodate different bearing outside diameters, three tool sizes are available:

Available transport and mounting tools

Designation	Bearing outside diameter		Bearing mass max. kg	Operating temperature max. °C	Tool mass kg
	min. mm	max. mm			
BEARING-MATE250-450	250	450	500	160	6,3
BEARING-MATE450-650	450	650	500	160	6,4
BEARING-MATE650-850	650	850	500	160	6,5

Scope of delivery

The scope of delivery of BEARING-MATE comprises:

- transport and mounting tool BEARING-MATE
- two brackets to prevent tilting of the inner rings of self-aligning bearings
- heat-resistant protective gloves.



Figure 20
Scope of delivery
BEARING-MATE

Available accessories

Description	Designation
Long brackets to prevent tilting of inner rings of self-aligning bearings (2 pieces)	BEARING-MATE.LOCKBAR270
Carrying sling 1 m long (2 pieces)	BEARING-MATE.SLING-1M

Available replacement parts

Description	Designation
Short brackets to prevent tilting of inner rings of self-aligning bearings (2 pieces)	BEARING-MATE.LOCKBAR170
Kit of replacement parts	BEARING-MATE.SERVICE-KIT

Heating devices HEATER

FAG infrared thermometer TEMP-CHECK-PRO

The FAG infrared thermometer TEMP-CHECK-PRO is suitable for the thermal monitoring of machine components and fluids. Temperatures can be measured by either non-contact or contact means.

The surface temperature sensor can be used to measure the temperature of surfaces by contact means.

The features of FAG TEMP-CHECK-PRO are as follows:

- state of the art infrared temperature technology with high precision glass optics for precise non-contact temperature measurement
- small measurement spot of 13 mm at a distance of up to 260 mm
- measurement spot size corresponds to 40:1 (distance: measurement spot size) at a distance of more than 260 mm
- rapid, precise temperature measurement over a temperature range of -32 °C to $+760\text{ °C}$ (-20 °F to 1440 °F)
- degree of emission adjustable to material
- additional temperature sensors for contact measurements
- low mass (150 g), easy to handle
- USB interface, memory, report software
- low purchase costs.



Figure 21
Infrared thermometer
TEMP-CHECK-PRO

The device is suitable for measuring the temperature of:

- rolling bearings, housings and lubrication systems for the purposes of operational monitoring
- heated rolling bearings and joints during mounting.

Other applications

The heating devices can also be used to heat rolling bearings with a mass of more than 1 200 kg and rotationally symmetrical steel parts such as:

- labyrinth rings
- gears
- roll couplings
- sleeves.

If rolling bearings with a mass of more than 1 200 kg or rotationally symmetrical steel parts are to be heated, please consult us for correct device selection.

Ask us about the appropriate heating device if these points apply:

- rolling bearings with a mass of more than 1 200 kg
- heating temperature higher than +240 °C
- workpiece other than a rolling bearing
- different material
- different power supply.

The checklist in the appendix can be used in the selection of the appropriate heating device.

Heating devices HEATER

Design and safety guidelines Safety and reliability

All induction heating devices generate magnetic fields. The magnetic field can have a negative effect on pacemakers and watches, mobile telephones, car keys, credit cards and other data carriers as well as electronic circuits in instruments.

Safety for users

The user is protected against the magnetic induction field as follows:

- HEATER10 and HEATER20:
The heating operation starts 5 s after the Start key is pressed, in order that the user can move out of range of the magnetic field.
- HEATER40 to HEATER1200:
The heating operation is started and stopped from a safe distance using an infrared remote control unit, *Figure 22*.

Note!

The safe distance from the induction heating device is 2 m.



Figure 22
Remove control unit
HEATER40 to HEATER1200

Protection of device

Protection of the heating device:

- The coil is not in the immediate vicinity of the workpiece to be heated, which prevents overheating of the heating device, *Figure 23*.
- The temperatures of the cooling element, coil and housing are continuously monitored. If the device overheats, the thermal protection system will switch it off before any component is damaged. Once the thermal protection system has been triggered, the heating device can be put back into operation once the error has been eliminated and the device has been checked.
- An error message is generated if the temperature curve does not correspond to the set value since the workpiece mass is too large (this only applies in the case of temperature control).

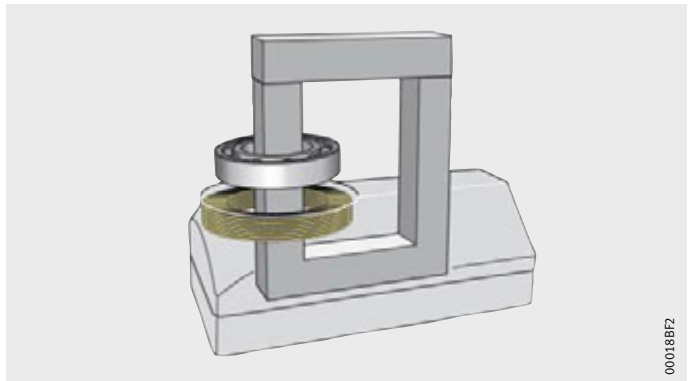

Figure 23
Mounting position
of the induction coil

Protection of rolling bearing

Protection of the rolling bearing:

- Uniform heating of the rolling bearing
- Against overheating if the temperature sensor is not correctly positioned, see section Attaching the temperature sensor, page 5
- Against overheating if the temperature sensor or sensor cable is damaged
- Against large temperature differentials between the inner and outer ring through the use of ramp control. This avoids the risk of material damage such as stresses or raceway damage due to the indentation of rolling elements.

Heating devices HEATER

Reliability of machinery The correct mounting of rolling bearings leads to an increase in:

- the reliability of plant and
- machine availability.

Warranty The warranty period of the heating devices HEATER10 to HEATER1200 can be extended, free of charge, to **five years**.



Figure 24
Warranty



Conformity The induction heating devices HEATER fulfil the essential health and safety requirements of the relevant EU directives and are certified in accordance with TÜV.

The devices also fulfil the requirements of the US safety standards and have UL certification.

Heating devices HEATER

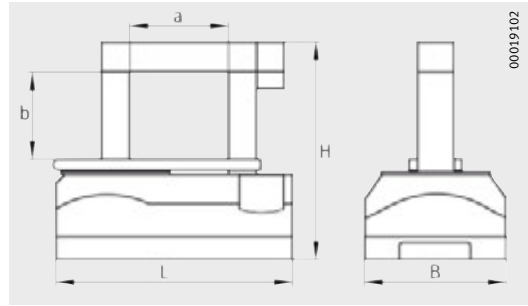
Product range



Dimension table				
Characteristics		Unit	HEATER10	HEATER20
				
Operating voltage	U	V	230	230
Frequency	F	Hz	50	50
Power consumption	P	kVA	2,3	3,6
Nominal current	I	A	10	16
Residual magnetism	H	A/cm	< 2	< 2
Duty cycle	ED	%	100	100
Mass	m	kg	7	17
Length	L	mm	240	345
Width	B	mm	200	205
Height	H	mm	255	230
Dimension	a	mm	65	120
Dimension	b	mm	100	100
Maximum rolling bearing mass	m	kg	10	20
Minimum rolling bearing bore (ledge)	d	mm	15	20
Minimum rolling bearing bore with accessories	d	mm	10	10
Minimum rolling bearing bore (lying flat)	d	mm	45	65
Maximum rolling bearing outside diameter	D	mm	165 (with LEDGE-45)	290 (with LEDGE-60)
Temperature control adjustable, with safety mechanism for rolling bearings	-	-	+40 °C to +240 °C	+40 °C to +240 °C
Time control	-	-	-	-
Ramp control	-	-	-	-



HEATER40	HEATER150	HEATER300	HEATER600	HEATER1200
				
230	400	400	400	400
50	50	50	50	50
3,6	12,8	12,8	25	40
16	25	32	63	100
< 2	< 2	< 2	< 2	< 2
100	100	100	100	100
26	57	75	350	850
340	500	1 045	1 300	1 660
240	290	310	820	1 040
295	480	570	1 080	1 245
180	210	330	430	700
160	210	260	400	450
40	150	300	600	1 200
20	45	115	150	225
15	20	30	55	95
80	110	125	–	–
410 (with LEDGE-70)	515 (with LEDGE-100)	740 (with LEDGE-115)	900 (with LEDGE-150)	1 500 (with LEDGE-225)
+40 °C to +240 °C	+40 °C to +240 °C	+40 °C to +240 °C	+40 °C to +240 °C	+40 °C to +240 °C
adjustable up to 99 min	adjustable up to 99 min	adjustable up to 99 min	adjustable up to 99 min	adjustable up to 99 min
adjustable up to 99 min and 240 °C	adjustable up to 99 min and 240 °C	adjustable up to 99 min and 240 °C	adjustable up to 99 min and 240 °C	adjustable up to 99 min and 240 °C

Heating devices HEATER

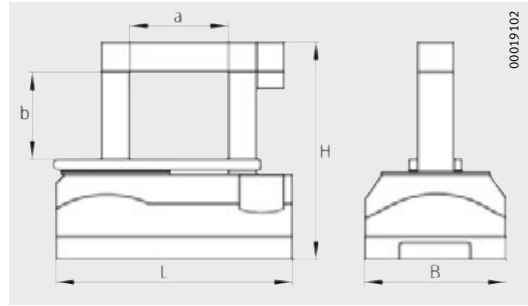
Product range



Dimension table

Characteristics		Unit	HEATER10-115V-UL	HEATER20-115V-UL
				
Operating voltage	U	V	115	115
Frequency	F	Hz	60	60
Power consumption	P	kVA	2,2	2,2
Nominal current	I	A	10	15
Residual magnetism	H	A/cm	< 2	< 2
Duty cycle	ED	%	100	100

HEATER40-115V-UL	HEATER150-460V-UL	HEATER300-460V-UL	HEATER600-460V-UL	HEATER1200-460V-UL
				
115	460	460	460	460
60	60	60	60	60
2,2	9,2	14,7	28,9	46
15	20	30	50	85
< 2	< 2	< 2	< 2	< 2
100	100	100	100	100

Checklist for selection of heating devices HEATER



Contact details – customer

Company name	_____	Contact person	_____
Street, house number	_____	Telephone	_____
Postcode, town	_____	Fax	_____
Country	_____	E-mail	_____

Contact details – Sales employee

Contact person	_____	Telephone	_____
Department	_____	Fax	_____
Plant	_____	E-mail	_____

Dates

Date of enquiry	_____	Date required	_____
-----------------	-------	---------------	-------

Technical data of workpieces to be heated

	Smallest workpiece	Largest workpiece
Maximum outside diameter in mm	_____	_____
Minimum bore diameter in mm	_____	_____
Maximum width in mm	_____	_____
Mass in kg	_____	_____
Material	_____	_____

Available technical documents

Application drawings	<input type="checkbox"/> yes	<input type="checkbox"/> no	_____
Dimension tables	<input type="checkbox"/> yes	<input type="checkbox"/> no	_____
Images	<input type="checkbox"/> yes	<input type="checkbox"/> no	_____

Operating requirements

Required heating temperature in °C	_____
Maximum required heating time in minutes	_____
Number of workpieces to be heated per hour or day	_____

Available power supply

Voltage in V	_____
Frequency in Hz	_____
Current in A	_____

Mounting tools used previously

Comments

_____	_____
_____	_____
_____	_____

Checklist for selection of heating devices HEATER



Contact details – customer

Company name	_____	Contact person	_____
Street, house number	_____	Telephone	_____
Postcode, town	_____	Fax	_____
Country	_____	E-mail	_____

Contact details – Sales employee

Contact person	_____	Telephone	_____
Department	_____	Fax	_____
Plant	_____	E-mail	_____

Dates

Date of enquiry	_____	Date required	_____
-----------------	-------	---------------	-------

Technical data of workpieces to be heated

	Smallest workpiece	Largest workpiece
Maximum outside diameter in mm	_____	_____
Minimum bore diameter in mm	_____	_____
Maximum width in mm	_____	_____
Mass in kg	_____	_____
Material	_____	_____

Available technical documents

Application drawings	<input type="checkbox"/> yes	<input type="checkbox"/> no	_____
Dimension tables	<input type="checkbox"/> yes	<input type="checkbox"/> no	_____
Images	<input type="checkbox"/> yes	<input type="checkbox"/> no	_____

Operating requirements

Required heating temperature in °C	_____
Maximum required heating time in minutes	_____
Number of workpieces to be heated per hour or day	_____

Available power supply

Voltage in V	_____
Frequency in Hz	_____
Current in A	_____

Mounting tools used previously

Comments

_____	_____
_____	_____
_____	_____

Checklist for selection of heating devices HEATER



Contact details – customer

Company name	_____	Contact person	_____
Street, house number	_____	Telephone	_____
Postcode, town	_____	Fax	_____
Country	_____	E-mail	_____

Contact details – Sales employee

Contact person	_____	Telephone	_____
Department	_____	Fax	_____
Plant	_____	E-mail	_____

Dates

Date of enquiry	_____	Date required	_____
-----------------	-------	---------------	-------

Technical data of workpieces to be heated

	Smallest workpiece	Largest workpiece
Maximum outside diameter in mm	_____	_____
Minimum bore diameter in mm	_____	_____
Maximum width in mm	_____	_____
Mass in kg	_____	_____
Material	_____	_____

Available technical documents

Application drawings	<input type="checkbox"/> yes	<input type="checkbox"/> no	_____
Dimension tables	<input type="checkbox"/> yes	<input type="checkbox"/> no	_____
Images	<input type="checkbox"/> yes	<input type="checkbox"/> no	_____

Operating requirements

Required heating temperature in °C	_____
Maximum required heating time in minutes	_____
Number of workpieces to be heated per hour or day	_____

Available power supply

Voltage in V	_____
Frequency in Hz	_____
Current in A	_____

Mounting tools used previously

Comments

_____	_____
_____	_____
_____	_____

**Schaeffler Technologies
AG & Co. KG**

Postfach 1260
97419 Schweinfurt
Germany

Georg-Schäfer-Straße 30
97421 Schweinfurt
Germany

Phone +49 2407 9149-66
Fax +49 2407 9149-59
E-mail industrial-services@schaeffler.com
Internet www.schaeffler.com/services

Every care has been taken to ensure the correctness of the information contained in this publication but no liability can be accepted for any errors or omissions. We reserve the right to make technical changes.

© Schaeffler Technologies AG & Co. KG
Issued: 2012, May

This publication or parts thereof may not be reproduced without our permission.
TPI 200 GB-D